

**RK05
disk drive
maintenance manual**

DEC-00-HRK05-C-D

digital equipment corporation · maynard, massachusetts

Preliminary Edition, April 1972
2nd Printing, June 1972
3rd Printing, October 1972
4th Printing, December 1972
Second Edition, February 1973
6th Printing, October 1973
Third Edition, May 1974

Copyright © 1972, 1973, 1974 by Digital Equipment Corporation

The material in this manual is for informational purposes and is subject to change without notice.

Digital Equipment Corporation assumes no responsibility for any errors which may appear in this manual.

Printed in U.S.A.

The following are trademarks of Digital Equipment Corporation, Maynard, Massachusetts:

DEC	PDP
FLIP CHIP	FOCAL
DIGITAL	COMPUTER LAB

CONTENTS

	Page
CHAPTER 1	GENERAL INFORMATION
1.1	INTRODUCTION 1-1
1.2	WARRANTY 1-1
1.3	SPECIFICATIONS 1-1
1.4	50/60 Hz POWER OPTION 1-1
1.5	MAJOR ASSEMBLIES AND SYSTEMS 1-1
1.5.1	Controls and Indicators 1-4
1.5.2	Spindle and Drive 1-4
1.5.3	Linear Positioner 1-4
1.5.4	Cartridge-Handling System 1-4
1.5.5	Logic Assembly 1-4
1.5.6	Air System 1-4
1.5.7	Power Supply 1-4
1.5.8	Read/Write Heads 1-4
CHAPTER 2	INSTALLATION
2.1	UNPACKING AND INSPECTION 2-1
2.2	MECHANICAL INSTALLATION AND CHECKOUT 2-3
2.3	CARTRIDGE HANDLING PRACTICES AND PRECAUTIONS 2-6
2.4	CARTRIDGE PACKING AND SHIPPING 2-6
2.5	NORMAL OPERATING PROCEDURES 2-7
2.5.1	Cartridge Loading 2-7
2.5.2	Cartridge Unloading 2-7
CHAPTER 3	INTERFACE
3.1	GENERAL 3-1
3.2	INPUT INTERFACE LINES 3-1
3.2.1	RK11-D 3-1
3.2.2	Select (4 lines) 3-1
3.2.3	Cylinder Address (8 lines) 3-1
3.2.4	Strobe 3-1
3.2.5	Head Select 3-3
3.2.6	Write Protect Set 3-3
3.2.7	Write Data and Clock 3-3
3.2.8	Write Gate 3-3
3.2.9	Restore (RTZ) 3-3
3.2.10	Read Gate 3-3
3.3	OUTPUT INTERFACE LINES 3-3
3.3.1	File Ready (Drive Ready) 3-3
3.3.2	Read, Write, or Seek Ready/On Cylinder 3-3
3.3.3	Address Accepted 3-3
3.3.4	Address Invalid (Logic Address Interlock) 3-3
3.3.5	Seek Incomplete 3-3
3.3.6	Write Protect Status 3-3
3.3.7	Write Check 3-3
3.3.8	Read Data 3-4
3.3.9	Read Clock 3-4

CONTENTS (Cont)

		Page
3.3.10	Sector Address (4 lines)	3-4
3.3.11	Sector Pulse	3-4
3.3.12	Index Pulse	3-4
3.3.13	AC Low	3-4
3.3.14	DC Low	3-4
3.3.15	High Density/RK05 L	3-4
CHAPTER 4	THEORY OF OPERATION	
4.1	FUNCTIONAL DESCRIPTION	4-1
4.1.1	Start	4-1
4.1.2	Stop	4-1
4.1.3	Track Addressing and Head Positioning	4-1
4.1.4	Recording Technique	4-5
4.2	LOGICAL DESCRIPTION	4-5
4.2.1	Power On/Off Sequence	4-5
4.2.2	Start	4-5
4.2.3	Stop	4-5
4.2.3.1	Normal Stop	4-5
4.2.3.2	Low Speed Stop	4-9
4.2.3.3	AC Low Stop	4-10
4.2.3.4	DC Low Stop	4-10
4.2.4	Disk Drive Addressing	4-10
4.2.4.1	RK11-D Address Selection	4-10
4.2.4.2	RK11-C or RK8/E Address Selection	4-10
4.2.5	Seek	4-10
4.2.5.1	Load Heads Seek	4-10
4.2.5.2	Forward Seek	4-11
4.2.5.3	Reverse Seek	4-12
4.2.5.4	Return-to-Zero (Restore) Seek	4-12
4.2.6	Sector/Index Pulse Generation	4-12
4.3	CARRIAGE POSITIONING	4-14
4.3.1	Positioner Servo Description	4-14
4.3.1.1	Velocity Mode	4-14
4.3.1.2	Detent Mode	4-14
4.3.2	Servo Circuit Description	4-15
4.3.2.1	Linear Positioner Transducer	4-15
4.3.2.2	Velocity Function Generator	4-15
4.3.2.3	Velocity Synthesizer	4-16
4.4	READ/WRITE	4-17
4.4.1	Read Operation	4-17
4.4.2	Write Operation	4-19
4.5	FAULT DETECTION	4-20
4.5.1	Current Fault	4-20
4.5.2	Positioner Lamp Fault	4-20
4.6	POWER SUPPLY DESCRIPTION	4-21

CONTENTS (Cont)

		Page
CHAPTER 5	MAINTENANCE	
5.1	RECOMMENDED TOOLS AND TEST EQUIPMENT	5-1
5.2	PREVENTIVE MAINTENANCE	5-1
5.2.1	500-Hour PM Procedure	5-1
5.2.2	1,500-Hour PM Procedure	5-1
5.2.3	3,000-Hour PM Procedure	5-4
5.2.4	Absolute Filter Removal and Replacement	5-5
5.3	CORRECTIVE MAINTENANCE	5-5
5.3.1	Linear Positioner	5-5
5.3.1.1	Positioner Removal	5-5
5.3.1.2	Positioner Replacement	5-5
5.3.2	Carriage	5-7
5.3.2.1	Carriage Removal	5-7
5.3.2.2	Carriage Replacement	5-8
5.3.2.3	Carriage Bearing Assembly Removal	5-8
5.3.2.4	Carriage Bearing Assembly Replacement	5-8
5.3.2.5	Transducer Block Removal and Replacement	5-10
5.3.3	Read/Write Heads	5-10
5.3.3.1	Head Removal, without Head Insertion Tool	5-10
5.3.3.2	Head Replacement, without Head Insertion Tool	5-10
5.3.3.3	Head Removal, with Head Insertion Tool	5-12
5.3.3.4	Head Replacement, with Head Insertion Tool	5-12
5.3.4	Spindle	5-13
5.3.4.1	Spindle Removal	5-13
5.3.4.2	Spindle Replacement	5-15
5.3.4.3	Spindle Ground (Carbon Brush) Removal and Replacement	5-15
5.3.5	Spindle Drive Motor	5-15
5.3.5.1	Motor Removal	5-15
5.3.5.2	Motor Replacement	5-15
5.3.5.3	Drive Belt Removal and Replacement	5-16
5.3.6	Blower Motor	5-17
5.3.6.1	Blower Removal	5-17
5.3.6.2	Blower Replacement	5-17
5.3.7	Power Supply Removal	5-17
5.3.8	Cartridge Cleaning	5-17
5.3.8.1	Cartridge Cleaning Procedure	5-17
5.3.8.2	Adverse Disk Conditions	5-20
5.4	ALIGNMENT, CHECKS, AND ADJUSTMENTS	5-20
5.4.1	Alignment Cartridges	5-20
5.4.1.1	RK05K-AC Alignment Cartridge	5-20
5.4.1.2	2315 CE Test Cartridge Shim Installation	5-21
5.4.2	Servo System Timing Checks and Adjustments	5-21
5.4.2.1	Dynamic Off-Line Checks and Adjustments	5-23
5.4.2.2	Static Tests and Adjustments	5-29
5.4.3	Read/Write Data Separator (G180 Card) Adjustment	5-29
5.4.4	Read/Write Head Check and Alignment	5-30
5.4.4.1	RK05K-AC Alignment Cartridge	5-30
5.4.4.2	2315 CE Pack	5-34
5.4.5	Index/Sector Timing Adjustment	5-37

CONTENTS (Cont)

		Page
5.4.5.1	RK05K-AC Alignment Cartridge	5-37
5.4.5.2	2315 CE Pack	5-38
5.4.6	Cartridge Receiver Alignment	5-39
5.5	SPARE PARTS	5-40
5.6	TROUBLESHOOTING	5-40
5.6.1	Power Supply	5-42
5.6.2	Controls and Indicators	5-42
5.6.3	Mechanical Checks	5-43
5.6.4	Electronic Checks	5-43

APPENDIX A GLOSSARY OF RK05 BACKPLANE CONNECTIONS

APPENDIX B RK8E/RK05 MAINTENANCE PROGRAM

APPENDIX C RK05/RK11 OSCILLATING SEEK PROGRAM

APPENDIX D THE RK05-TA OFF-LINE TESTER

APPENDIX E RK05 INTEGRATED CIRCUITS

ILLUSTRATIONS

Figure No.	Title	Page
1-1	Location of Major Assemblies and Systems	1-3
1-2	Controls and Indicators	1-6
1-3	Spindle and Drive System	1-7
1-4	Linear Positioner	1-7
1-5	Cartridge Handling System	1-8
1-6	Air System	1-9
1-7	Head Loading	1-9
1-8	Relationship of Disk Head, Disk, and Contaminants	1-10
2-1	Shipping Bracket and Shipping Strap Location	2-2
2-2	RK11C or RK11D Interface Cable Installation	2-3
2-3	Chassis Slide Mounting	2-4
2-4	RK8/E Interface Cable Installation	2-5
3-1	Controller/RK05 Disk Drive Interface Lines and Pin Assignments	3-2
4-1	Functional Block Diagram	4-2
4-2	Start Flow Chart	4-3
4-3	Stop Flow Chart	4-4
4-4	Seek Flow Chart	4-6
4-5	Return-to-Zero (Restore) Flow Chart	4-7
4-6	Read/Write Head	4-8
4-7	Simplified Read/Write Head Circuit	4-8
4-8	Double Frequency Pulse Relationship	4-8
4-9	Control and Interlock Block Diagram	4-9
4-10	Sector/Index Timing	4-13
4-11	Servo System Block Diagram	4-15

ILLUSTRATIONS (Cont)

Figure No.	Title	Page
4-12	Linear Positioner Transducer	4-15
4-13	Simplified Positioner Servo Logic	4-16
4-14	Velocity Profile	4-17
4-15	Simplified Data Separator Circuit	4-18
4-16	Read Waveforms	4-19
5-1	Prefilter	5-1
5-2	Absolute Filter Removal	5-4
5-3	Internal Power Supply Connections	5-6
5-4	Top View of RK05 with Cover Removed	5-7
5-5	Carriage Bearing Assembly Removal	5-9
5-6	Read/Write Head Replacement without Head Insertion Tool	5-11
5-7	Read/Write Head Replacement with Head Insertion Tool	5-13
5-8	Spindle Replacement	5-14
5-9	Carbon Brush Replacement	5-16
5-10	Blower Motor Removal	5-18
5-11	How to Read a Vernier	5-20
5-12	Negligible Runout	5-21
5-13	Considerable Runout	5-21
5-14	CE Test Cartridge Shim Installation	5-22
5-15	Sine Amplitude/Offset and Velocity Offset Waveform	5-26
5-16	Cosine Amplitude/Offset Waveform	5-27
5-17	Velocity Amplitude Waveform	5-27
5-18	Acceleration Waveform	5-27
5-19	Full Stroke Waveform	5-28
5-20	Full Stroke Position Waveform	5-28
5-21	Outer Limit Waveform	5-28
5-22	RK05K-AC Head Alignment Waveforms	5-31
5-23	Read/Write Head Adjustments	5-33
5-24	2315 CE Pack Head Alignment Waveforms	5-35
5-25	Index/Sector Waveform	5-38
5-26	Cartridge-to-Receiver Clearance	5-41
5-27	Cartridge Receiver Clearances	5-41
5-28	Troubleshooting Flow Chart	5-42
5-29	Door Locking Bar Location	5-44
5-30	Cartridge Seating Elements	5-44

TABLES

Table No.	Title	Page
1-1	Performance Specifications	1-2
1-2	Controls and Indicators	1-5
5-1	Recommended Tools and Test Equipment	5-2
5-2	Preventive Maintenance Schedule	5-3
5-3	Servo System Checks	5-22
5-4	Servo System Adjustments	5-25

CHAPTER 1

GENERAL INFORMATION

1.1 INTRODUCTION

The RK05 Disk Drive, which is designed and manufactured by Digital Equipment Corporation, is a self-contained, random-access, data storage device that is especially well suited for use in small or medium-size computer systems, data acquisition systems, terminals, and other storage applications. Operational power for this device is provided by a power supply located within the drive cabinet. The RK05 is available in four models, each of which operates on a different power line.

This compact, lightweight drive uses a high-density, single-disk, 12-sector or 16-sector cartridge as its storage medium. Two movable heads, one flying above the rotating disk surface and one below, can read or record up to 406 data tracks at 1500 rpm. The double-frequency, nonreturn-to-zero (NRZ) recording method used in this drive can store up to 25 million bits of on-line data. Data formatting is governed entirely by the operating system.

With the address select logic contained in each drive, up to eight RK05 Disk Drives (depending on the type of system) can be "daisy-chained" and operated from a single controller bus.

1.2 WARRANTY

"Removable media involve use, handling and maintenance which are beyond DEC's direct control. DEC disclaims responsibility for performance of the Equipment when operated with media not meeting DEC specifications or with media not maintained in accordance with procedures approved by DEC. DEC shall not be liable for damages to the Equipment or to media resulting from such operation."

1.3 SPECIFICATIONS

Table 1-1 lists the performance specifications of the RK05 Disk Drive for the 12-sector cartridge. Wherever applicable, a second specification pertaining to a 16-sector cartridge is also listed.

1.4 50/60 Hz POWER OPTION

The RK05 Disk Drive is available in the following four power models:

- RK05-AA 95 to 130 Vac @ 60 Hz
- RK05-AB 190 to 260 Vac @ 60 Hz
- RK05-BA 95 to 130 Vac @ 50 Hz
- RK05-BB 190 to 260 Vac @ 50 Hz

Each model is shipped with a complete set of drawings. To change from 50 to 60 Hz operation requires a different spindle drive pulley, and the motor must be moved as described in Paragraph 5.3.5. Changing from 115 V to 230 V operation requires that the power connector (P2) be reconfigured (Paragraph 4.6).

1.5 MAJOR ASSEMBLIES AND SYSTEMS

The RK05 Disk Drive is composed of the following major assemblies and systems:

- Controls and Indicators
- Spindle and Drive System
- Linear Positioner
- Cartridge Handling System
- Logic Assembly
- Air System
- Power Supply
- Read/Write Heads

Figure 1-1 illustrates the locations, and the subsequent paragraphs describe the functions of each of the major assemblies and systems.

**Table 1-1
Performance Specifications**

Characteristic	Specification
Storage Medium	
Type	Single disk magnetic cartridge
Disk Diameter	14 in.
Magnetic Heads	
Number	Two
Recording Density and Format	
Density	2200 bpi max.
Tracks	406 (200 plus 3 spares on each side of the disk)
Cylinders	203 (two tracks each)
Sectors (records)	4872 (12 per revolution)/6496 (16 per revolution)
Bit Capacities (unformatted)*	
Per Disk	25 million
Per Inch	2040 (max. at inner track)
Per Cylinder	115,200
Per Track	57,600
Per Sector	4,800/3,844
Access Times	
Disk Rotation	1500 ± 30 rpm
Average Latency	20 ms (half rotation)
Head Positioning	10 ms – for adjacent tracks
(including settling time)	50 ms – average
	85 ms – for 200 track movement
Bit Transfer*	
Transfer Code	Double frequency, nonreturn-to-zero recording
Transfer Rate	1.44M bits per sec
Electrical Requirements	
Voltage	115/230 Vac @ 50/60 Hz ± .05 Hz
Power	250 VA
Starting Current	Power only: 1.8 A Start spindle: 10 A (for 2 sec)
Model Designation	
RK05-AA	95 to 130 Vac @ 60 ± 0.5 Hz
RK05-AB	190 to 260 Vac @ 60 ± 0.5 Hz
RK05-BA	95 to 130 Vac @ 50 ± 0.5 Hz
RK05-BB	190 to 260 Vac @ 50 ± 0.5 Hz
Environment	
Ambient Temperature	50° to 110° F (10° to 43° C nominal)
Relative Humidity	8% to 80% (no condensation)
Barometric Pressure	10,000 ft (3,000 meters) max.
Temperature, Change Rate	10° F (6° C) per hr
Temperature, Interchangeable Range	30° F (17° C)
Dimensions and Weight	
Width	19 in. (48 cm)
Depth	26-1/2 in. (67 cm)
Height	10-1/2 in. (27 cm)
Weight	110 lb (50 kg)

*Some RK11-D systems record at 1.54M bits/sec which increases the bit density and capacity accordingly.

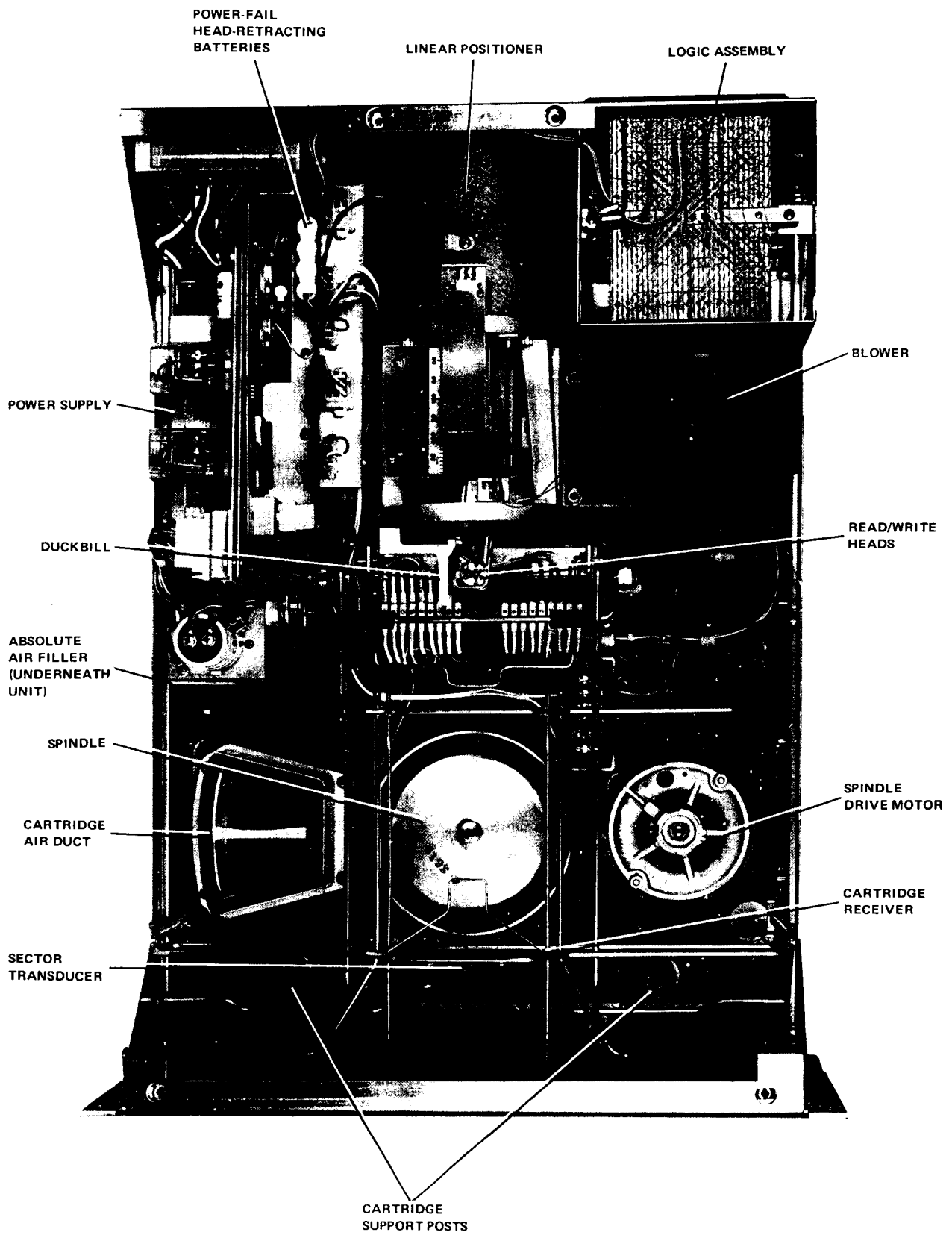

6858-6

Figure 1-1 Location of Major Assemblies and Systems

1.5.1 Controls and Indicators

The controls and indicators (Figure 1-2) required for normal operation are located on the front of the drive cabinet. Table 1-2 describes the function of each control or indicator.

1.5.2 Spindle and Drive

The spindle and drive system (Figure 1-3) is composed of the spindle, spindle drive motor, and the recording disk. A 50/60 Hz, split-phase ac motor transfers torque (via the drive belt) to the spindle drive pulley. Belt tension is maintained by a tension spring anchored to the baseplate.

The spindle speed is electronically tested by a circuit that measures the INDEX PULSE interval. When the interval increases to approximately 45 ms, indicating an unsafe speed, the drive is cycled down. If the RUN/LOAD switch is placed in the LOAD position, ac power is removed from the motor and the spindle coasts to a halt.

1.5.3 Linear Positioner

The linear positioner (Figure 1-1) consists of the linear motor, the carriage, the read/write heads, and the linear positioner transducer. To move the read/write heads across the recording disk, dc current is applied to the bobbin-wound armature (Figure 1-4) of the linear motor. The resulting magnetic field reacts with a permanent magnet in the motor housing to either pull the armature into or force it out of the permanent magnetic field, depending upon the polarity of the current applied to the armature. This motion is transferred to the carriage, which is fastened to the armature. As a result, the read/write heads, which are attached to the carriage, move across the surface of the disk.

Any carriage movement is detected by the linear positioner transducer, which is located on the underside of the carriage. The transducer output is used with the control logic to determine the cylinder position of the heads, and in the servo logic to govern the speed of carriage travel.

1.5.4 Cartridge-Handling System

The cartridge-handling system (Figure 1-5a) consists of a cartridge receiver, two receiver lifting cams, an access door opener, a duckbill, and two cartridge support posts. During normal operation, the plastic cartridge is located *only* by the duckbill and support posts. The cartridge receiver merely *guides* the cartridge into position to be picked up by the duckbill and support posts, allowing the recording disk to rotate freely on the spindle. The rotating spindle drives the disk by magnetic coupling at the disk hub.

As the drive front door is opened, the lifting cams rotate to elevate the receiver to a slanted position and the magnetic coupling at the disk hub is released. When the disk cartridge is inserted into the receiver (Figure 1-5b), the access door opener contacts the rear of the top cover, opening the access door to allow entry of the read/write heads.

As the drive front door is closed, the cartridge is lowered to the operating position, and the magnetic coupling again engages the disk hub. When the cartridge is in the operating position, the plastic case depresses the cartridge-on switch and removes the no-cartridge interlock condition. The cartridge receiver should *not* hold the cartridge tightly.

1.5.5 Logic Assembly

The logic assembly (Figure 1-1), located in the right rear portion of the disk drive, holds eight printed circuit cards. Three of these cards contain the system logic and the read/write circuits. Two cards contain the positioner servo logic. One card is the cable connector that interfaces the electronics with the positioner and other chassis-mounted components, while the remaining two cards contain the interface cables and terminators.

1.5.6 Air System

The air system (Figure 1-6) consists of the prefilter, blower, absolute filter, plenum chamber, and the cartridge air duct. As the blower rotates, unfiltered air is drawn through the prefilter, where it is purged of large dust particles. The prefiltered air is then circulated through the logic assembly and into the plenum. From there, the air passes through the absolute filter (where minute contamination is removed), up the cartridge air duct, and into the disk cartridge. Cooling air from the absolute filter is also shunted, by the plenum, through the linear positioner. Exhaust air exits through the front grill of the drive.

1.5.7 Power Supply

The power supply (Figure 1-1), located in the left rear portion of the disk drive, furnishes all the dc voltages for the drive. The power supply can operate with a 115 V or 230 V, 50 or 60 Hz line voltage input (Paragraph 4.6).

1.5.8 Read/Write Heads

There are two ramp-loaded read/write heads in the RK05 Disk Drive. One head functions on the top surface of the recording disk and the other on the bottom. The heads are mounted on suspension arms that rest, when the heads are unloaded, on a plastic cam block of the duckbill (Figure 1-7). Flat cantilever springs connect the suspension arms to the head-support tailpieces. When the drive is placed in the RUN mode, the positioner moves the heads forward toward cylinder zero. When the entire head slider pad has passed the edge of the disk, a ramp on the suspension arm slides down the edge of the plastic cam block, thereby moving (loading) the heads close to the disk surface. When loaded, the heads "fly" 80 to 100 microinches from the disk surface (Figure 1-8). A film of air (air bearing) between the disk and the head acts as a force away from the disk, while the cantilever spring is a counterbalancing force toward the disk. Thus, as long as the disk rotation remains constant the heads remain at a relatively constant distance away from the disk surface.

**Table 1-2
Controls and Indicators**

Controls and Indicators	Description
RUN/LOAD (rocker switch)	<p>Placing this switch in the RUN position (providing that all interlocks are safe):</p> <ul style="list-style-type: none"> a. locks the drive front door b. accelerates the disk to operating speed c. loads the read/write heads d. lights the RDY indicator. <p>Placing this switch in the LOAD position:</p> <ul style="list-style-type: none"> a. unloads the read/write heads b. stops the disk rotation c. unlocks the drive front door when the disk has stopped d. lights the LOAD indicator.
WT PROT (rocker switch – spring-loaded off)	<p align="center">CAUTION</p> <p>Do not switch to the LOAD position during a write operation; this results in erroneous data being recorded.</p> <p>Placing this momentary contact switch in the WT PROT position lights the WT PROT indicator and prevents a write operation; it also turns off the FAULT indicator, if that is lit.</p> <p>Depressing this switch in the WT PROT position a second time turns off the WT PROT indicator and allows a write operation.</p>
PWR (indicator) RDY (indicator)	<p>Lights when operating power is present. Goes off when operating power is removed.</p> <p>Lights when:</p> <ul style="list-style-type: none"> a. the disk is rotating at the correct operating speed. b. the heads are loaded. c. no other conditions are present (all interlocks safe) to prevent a seek, read, or write operation.
ON CYL (indicator)	<p>Goes off when the RUN/LOAD switch is set to LOAD.</p> <p>Lights when:</p> <ul style="list-style-type: none"> a. the drive is in the Ready condition. b. a seek or restore operation is not being performed. c. the read/write heads are positioned and settled. <p>Goes off during a seek or restore operation.</p>

Table 1-2 (Cont)
Controls and Indicators

Controls and Indicators	Description
FAULT (indicator)	<p>Lights when:</p> <ul style="list-style-type: none"> a. erase or write current is present without a WRITE GATE. b. the linear positioner transducer lamp is inoperative. <p>Goes off when the WT PROT switch is pressed, or when the drive is recycled through a RUN/LOAD sequence.</p>
WT PROT (indicator)	<p>Lights when:</p> <ul style="list-style-type: none"> a. the WT PROT switch is pressed. b. the operating system sends a Write Protect command. <p>Goes off when the WT PROT switch is pressed a second time, or when the drive is recycled through a RUN/LOAD sequence.</p>
LOAD (indicator)	<p>Lights when the read/write heads are fully retracted and the spindle has stopped rotating.</p>
WT (indicator)	<p>Lights when a write operation occurs. Goes off when the write operation terminates.</p>
RD (indicator)	<p>Lights when a read operation occurs. Goes off when the read operation terminates.</p>

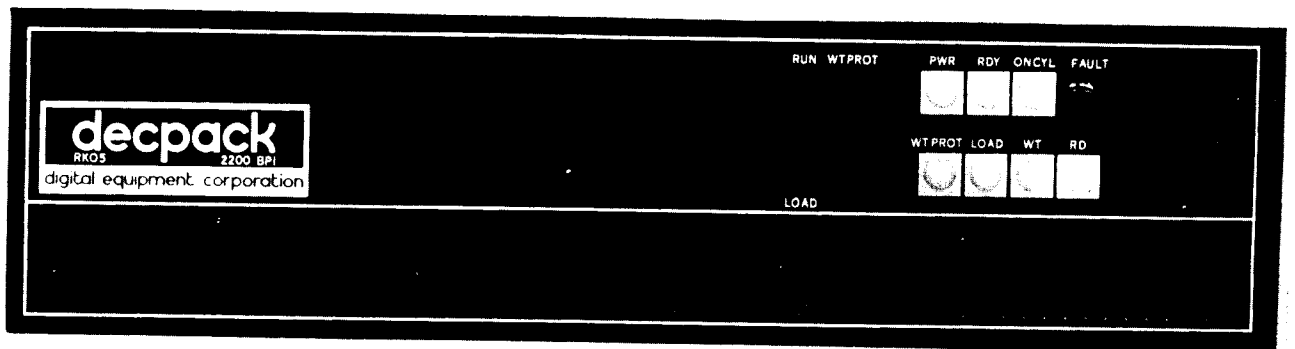

Figure 1-2 Controls and Indicators

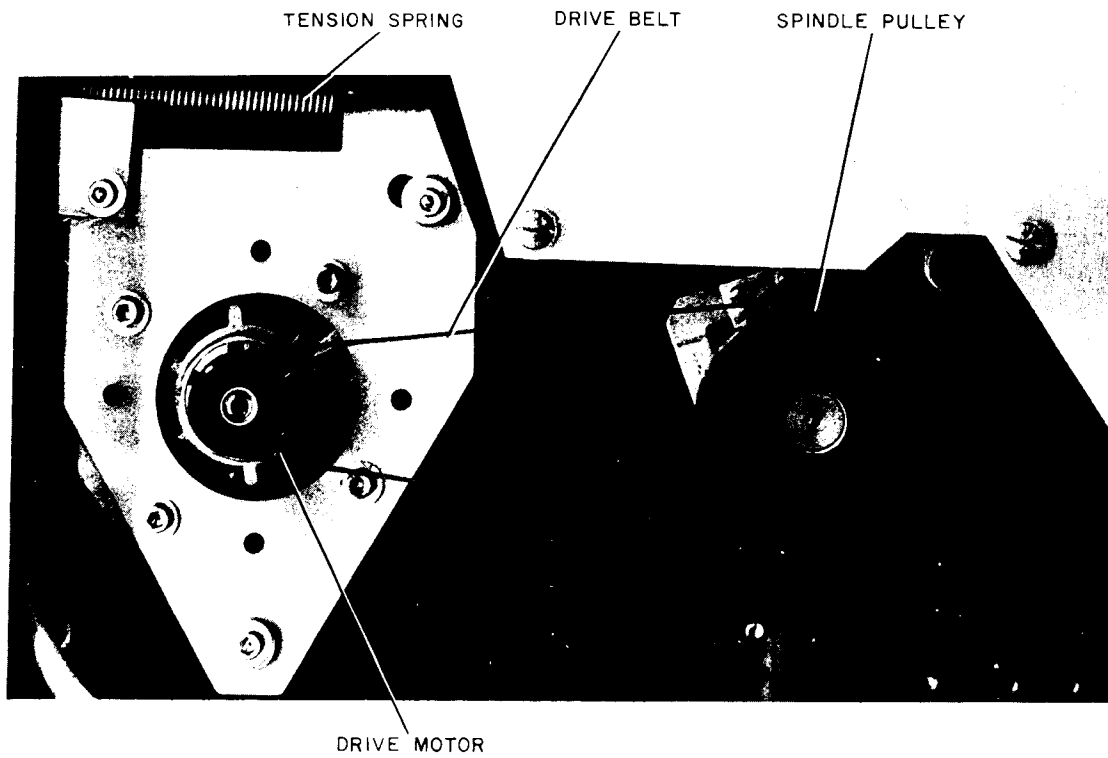
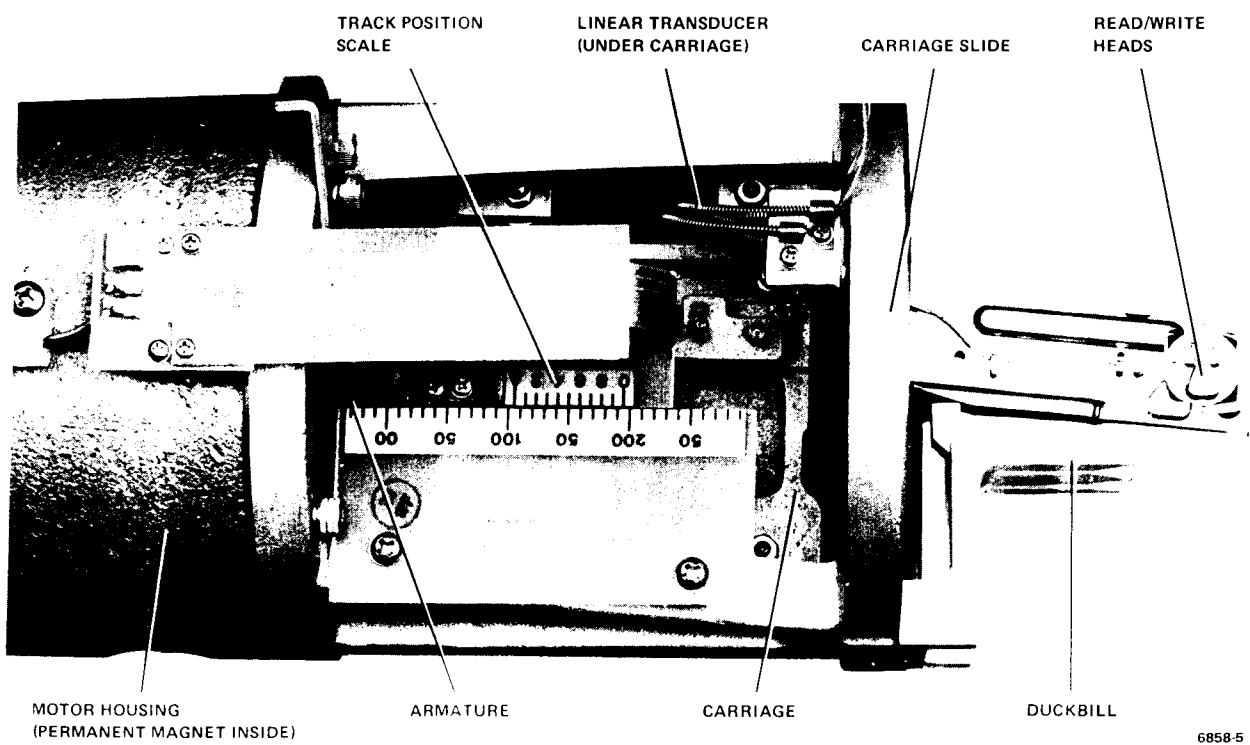
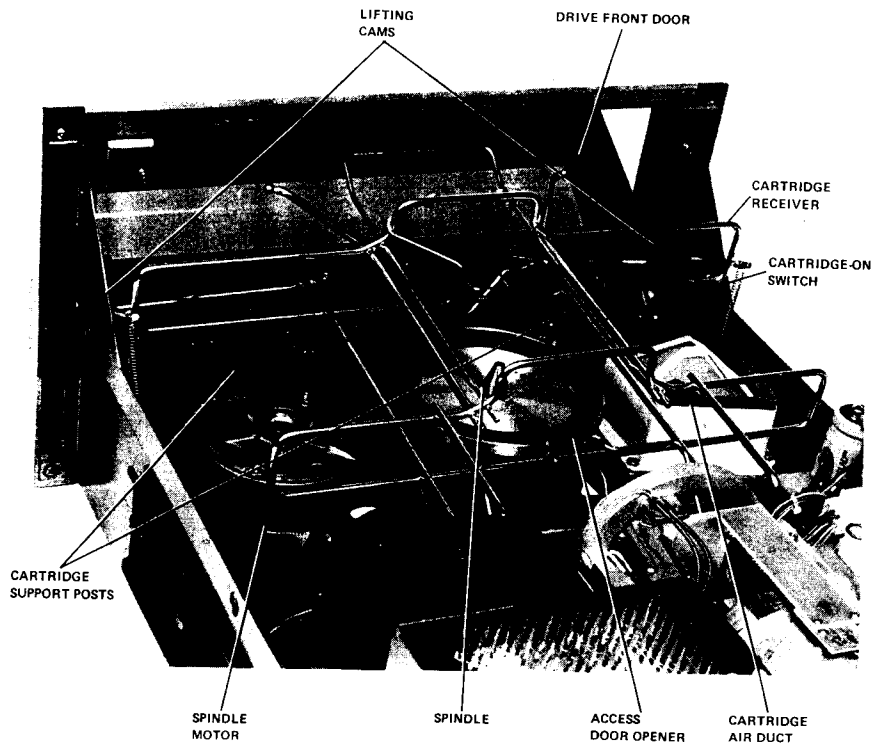

Figure 1-3 Spindle and Drive System



6858-5

Figure 1-4 Linear Positioner



a. Cartridge Removed

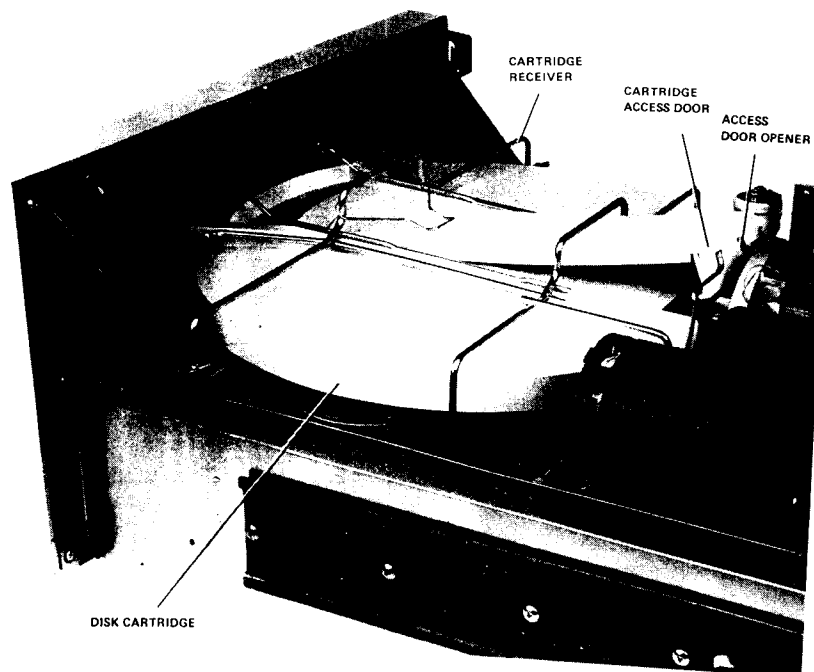

b. Cartridge Inserted

Figure 1-5 Cartridge Handling System

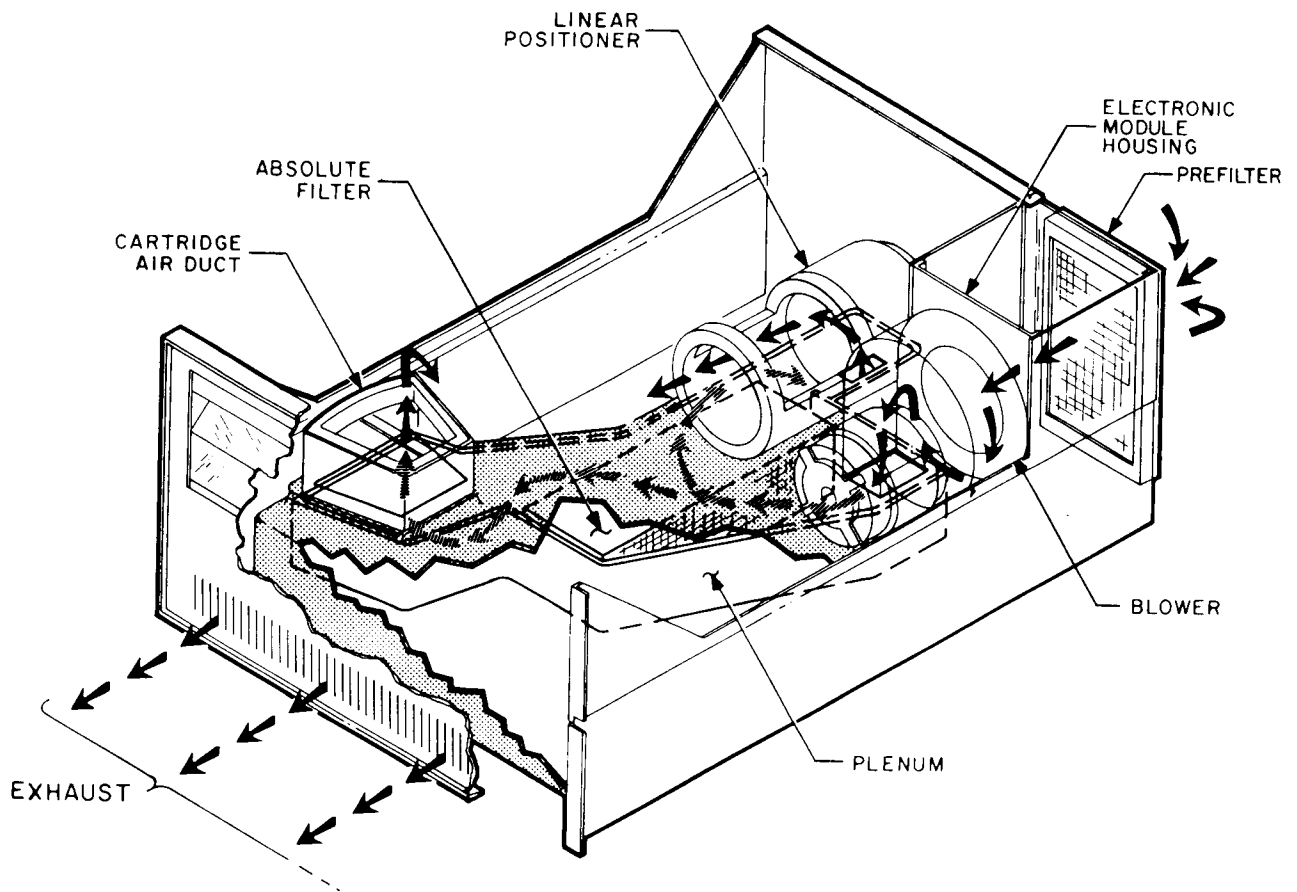

CP-0272

Figure 1-6 Air System

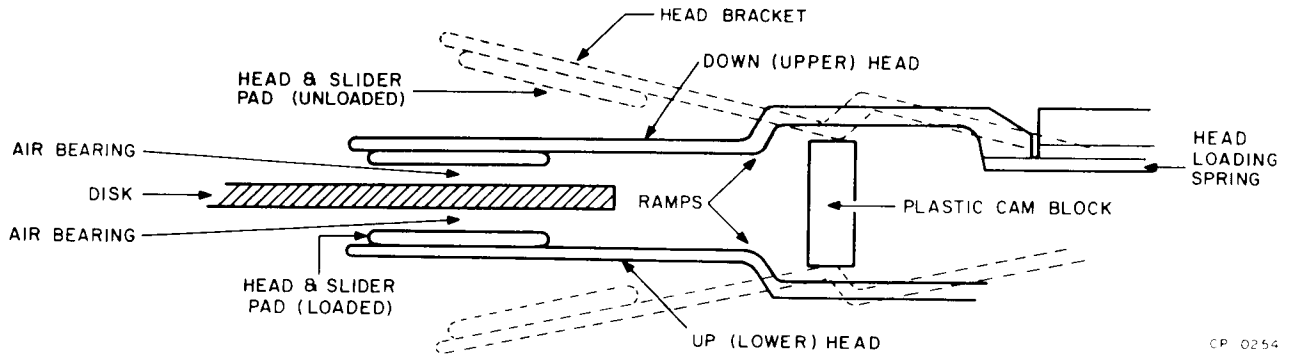

CP 0254

Figure 1-7 Head Loading

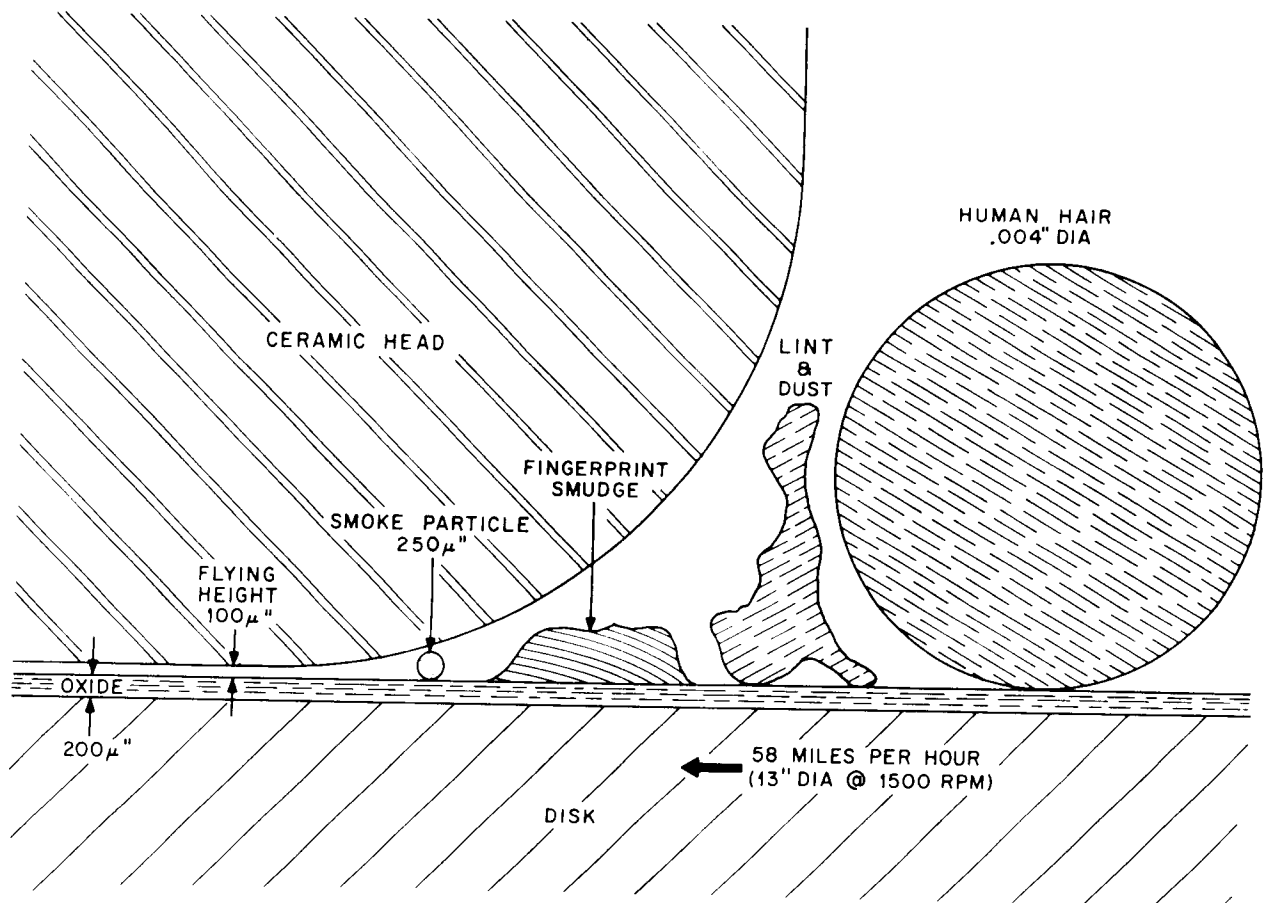

08-0884

Figure 1-8 Relationship of Disk Head, Disk, and Contaminants

The DOWN (UPPER) HEAD is so-called by convention throughout the computer industry because it faces down; the UP (LOWER) HEAD faces up. These designations were created to describe heads loaded onto a multisurface (10 or 20) cartridge.

The recording device (read/write head) is a coil-wound ferrite core with an air gap. As current flows through the

coil, the induced flux magnetizes the surface of the disk passing under the gap. During a write operation, when the current direction in the coil is reversed, a flux reversal is recorded on the disk. During a read operation, the previously-recorded flux pattern on the disk induces current in the head. Any flux reversal on the recording surface produces a pulse.

CHAPTER 2

INSTALLATION

2.1 UNPACKING AND INSPECTION

The RK05 Disk Drive can be shipped in a rack as an integral part of a system or in a separate container. If the drive is shipped in a rack, the rack should be positioned in the final installation location and unpacked as follows:

1. Remove the shipping brackets from the drive by removing the snap-on bezel beneath the lowest drive.
2. Remove the screws attaching the shipping bracket and latch molding to both sides of the drive.

CAUTION

Do not use the drive front door handle to pull the drive out from the rack.

3. Slide the drive out about 3 inches from the rack and pull the shipping brackets out from the sides of the drive. Attach the latch molding back onto the drive with the shipping bracket screws.
4. Slide the lowest drive out far enough to gain access to the shipping brackets on the drive directly above it and remove the screws from these two shipping brackets.
5. Repeat Steps 3 and 4 for each drive in the rack.
6. Remove the drive bottom cover and remove the screws that attach the three internal shipping brackets to the baseplate (Figure 2-1a).

CAUTION

Do not operate drive with shipping brackets attached.

7. If RK05 drives are "daisy-chained" with RK03 drives in a multidrive installation, arrange the RK05s consecutively at the controller end of the bus to avoid interruption of the AC LOW and DC LOW interface lines, which are not carried by the RK03s. If this arrangement is not possible, all RK05s that are separated on the bus by RK03s must be connected by separate cables between their J06 connections (Figure 2-2).
8. Remove the drive top cover and remove the mounting screw and shipping strap from the linear positioner (Figure 2-1b). Turn the shipping strap upward and replace it on the linear positioner, making sure it is tightly secured.
9. Retain all packing material for possible reshipment. Inspect the drive for possible damage. Report any damage to the carrier and to Digital Equipment Corporation.
10. In the case of RK05 Disk Drive relocation or reshipment, replace the shipping brackets and shipping strap in the shipping position; repeat this unpacking and inspection procedure when the drive is reinstalled.

If the drive is shipped in a separate container, use care while unpacking it. Do not drop the drive or subject it to unreasonable impact.

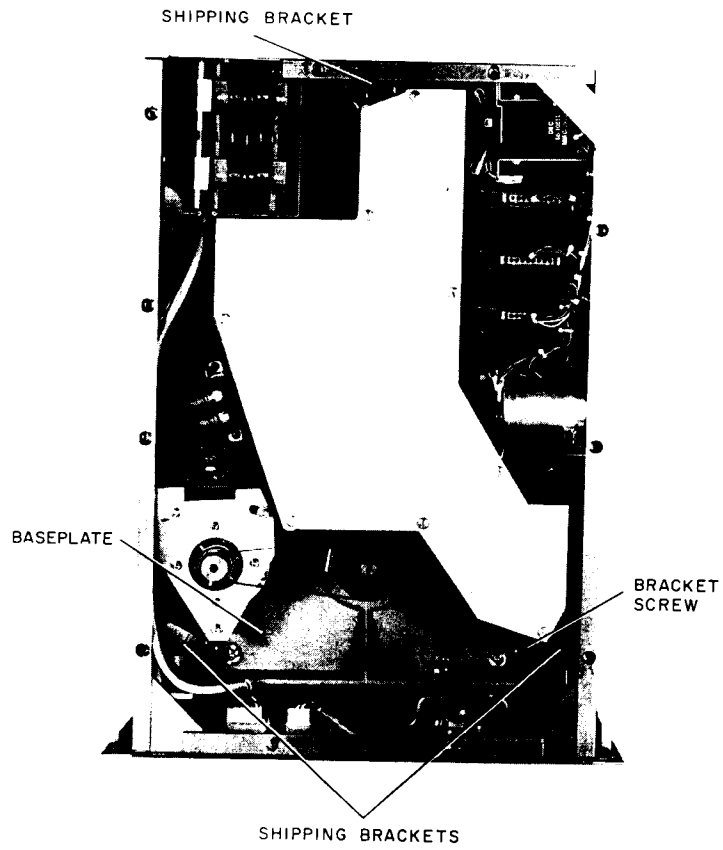

a. Shipping Brackets

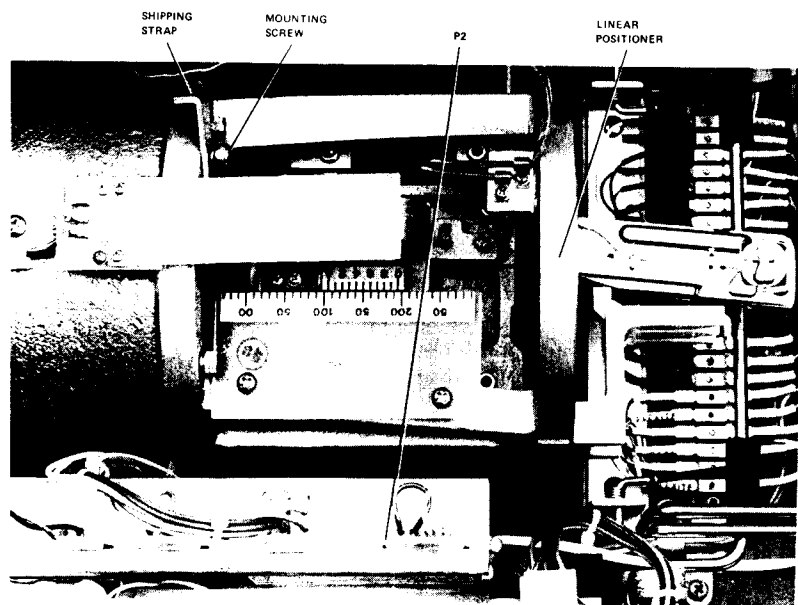

b. Shipping Strap

Figure 2-1 Shipping Bracket and Shipping Strap Locations

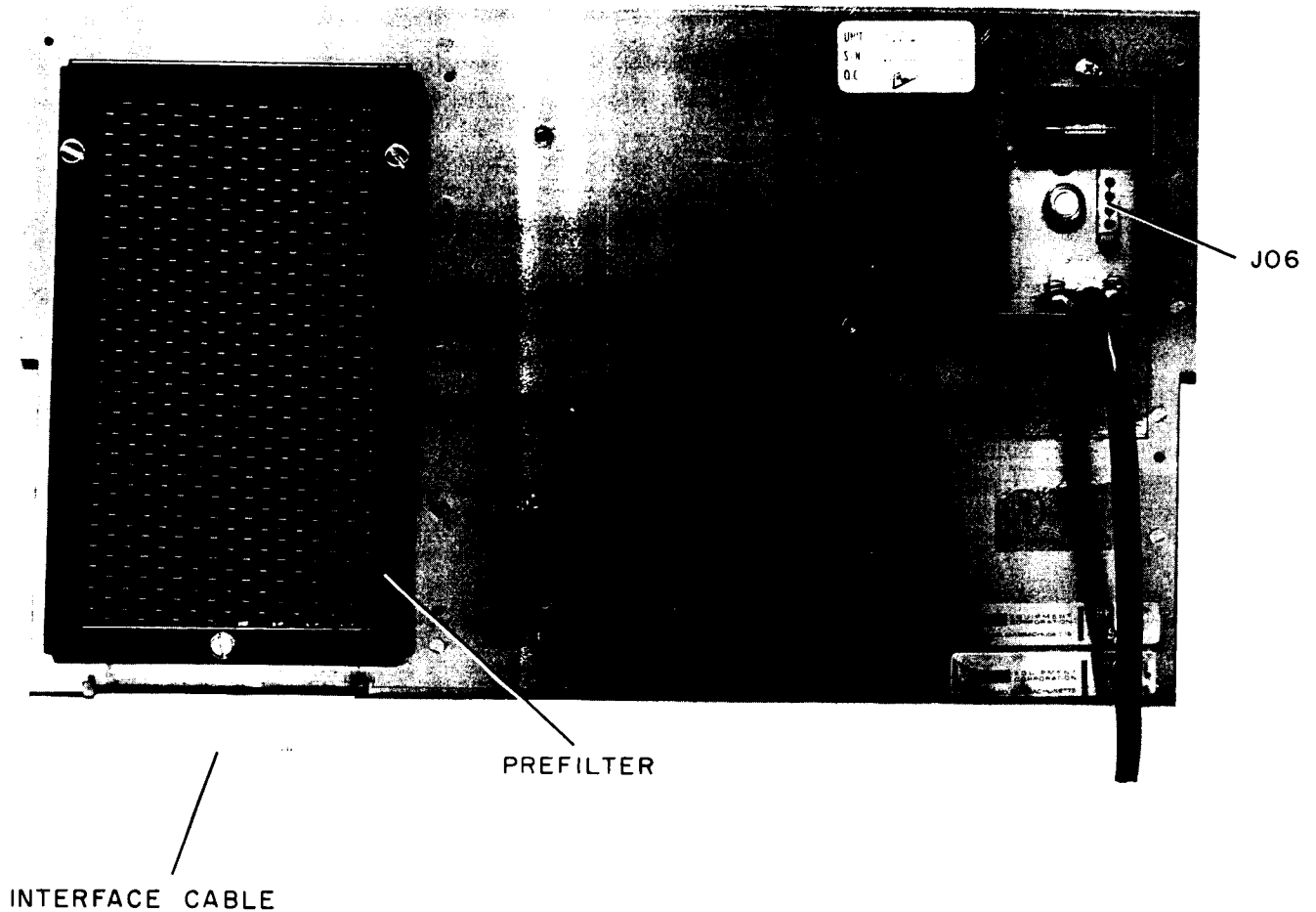

Figure 2-2 RK11C or RK11D Interface Cable Installation

2.2 MECHANICAL INSTALLATION AND CHECKOUT

If the RK05 Disk Drive is to be installed in an existing rack, the chassis slides should first be installed in the rack (Figure 2-3). The disk drive should be mounted on the chassis slides as follows: (If necessary, refer to the RK05 Option Configuration Dwg. No. D-OC-RK05-0-15 for detailed mechanical specifications of a multidrive installation.)

1. Install cabinet stabilizers before mounting the drive, unless the weight of the rack is sufficient to prevent tipping when the drive is fully extended.
2. Pull the chassis slides out until they lock in the extended position.
3. Slide the drive onto the chassis slides until it locks.
4. Remove the drive bottom cover and remove the screws that attach the three internal shipping brackets to the baseplate (Figure 2-1a).
5. Remove the drive top cover and remove the mounting screw and shipping strap from the linear positioner (Figure 2-1b). Turn the shipping strap upward and replace it on the linear positioner. Pull the heads forward as far as possible without going off the ramp (Figure 1-7) and confirm that the batteries (Figure 1-1) return the heads to the home position.

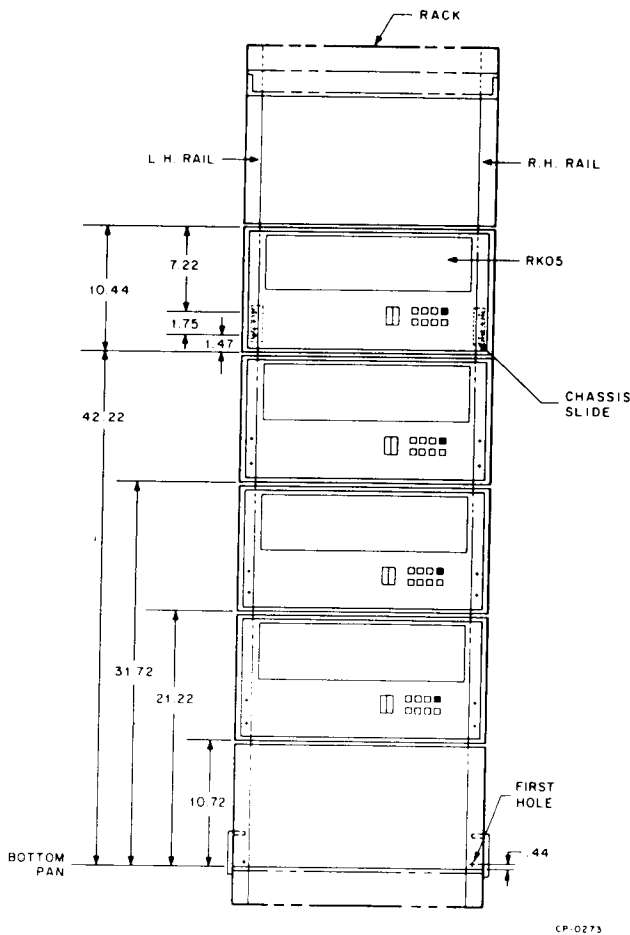

Figure 2-3 Chassis Slide Mounting

6. Inspect P2 (Figure 5-3) and the spindle pulley to ensure that the drive is configured properly for the input power to be used. If P2 contains two jumpers, the supply is configured for 115 Vac operation. If P2 contains only one jumper, the supply is configured for 230 Vac. The operating frequency is stamped on the spindle pulley.
7. Check the logic assembly to ensure that no pins are bent or broken, and then plug the interface cable card into card position 7 or 8 of the logic assembly. If there is only one drive in the system, or if this is the last drive of the daisy-chain, ensure that an M930 terminator card (Dwg. No. RK05-0-2) is in the unused interface card position.

8. If RK05 drives are daisy-chained with RK03 drives in a multidrive installation, arrange the RK05s consecutively at the controller end of the bus to avoid interruption of the AC LOW and DC LOW interface lines, which are not carried by the RK03s. If this arrangement is not possible, connect all RK05s that are separated on the bus by RK03s by means of separate cables between their J06 connections (Figure 2-2).
9. If the drive is to be connected to other than an RK11-C or RK11-D controller, install the interface cables as follows:
 - a. Remove the prefilter and frame.
 - b. Route the interface cables through the prefilter opening and reinstall the filter and frame so that the cables fit into the slot on the side of the frame (Figure 2-4).
 - c. Route the cables over the prefilter and fold them as indicated in Figure 2-4.
 - d. Place the cable retaining bracket over the fold in the cables and fasten the bracket to the chassis.
10. If the drive is to be connected to an RK11-C or RK11-D controller, install the interface cables either as described in Step 9, above, (which is preferable) or as follows:
 - a. Fold the interface cables and route them through the slot just below the prefilter at the rear of the drive cabinet (Figure 2-4).
 - b. Hold the cables in position and replace the bottom cover.
11. To avoid random errors, confirm that the grounding strap is firmly in place between the base plate and the chassis, and that brushes are mounted securely and in the proper plane. Confirm that all connectors are securely in place.
12. Configure the M7700 select switch to address a valid drive (Paragraph 3.2.2).
13. Plug the power cord into the switched ac line receptacle.

A = SINGLE FOLD
B = DOUBLE FOLD

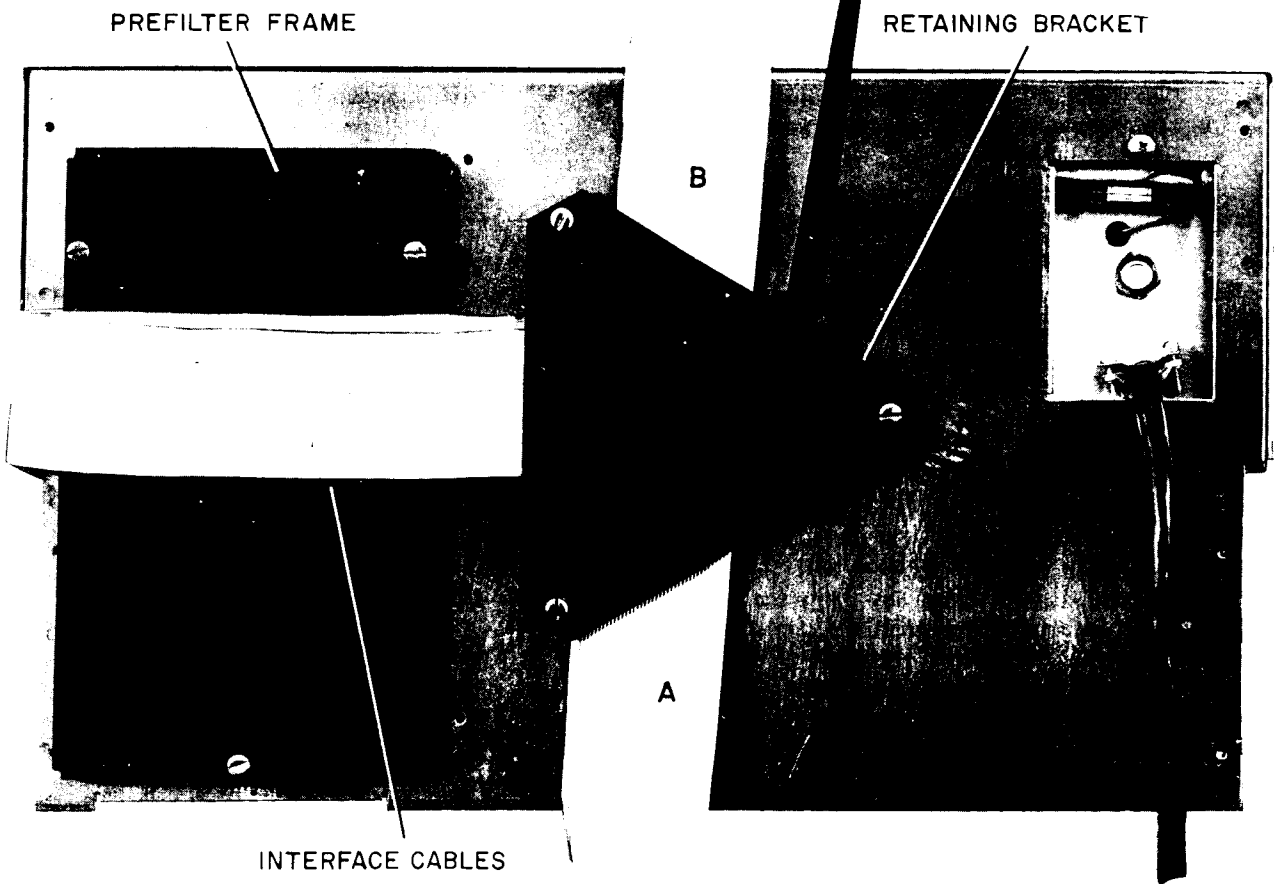
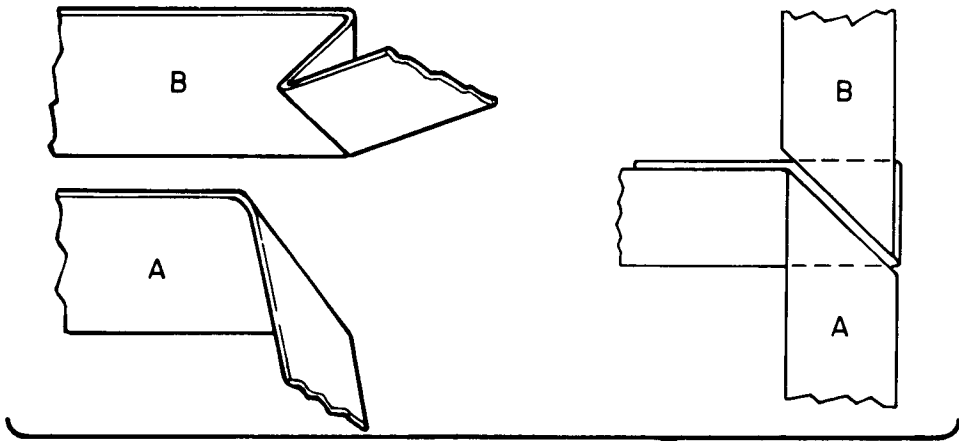

Figure 2-4 RK8/E Interface Cable Installation

14. Turn the processor keyswitch ON to apply power to the drive.
15. Check that the spindle is clean, and that the heads are not bent or dirty.
16. Install a test cartridge on the spindle (Paragraph 5.4.1) and check the head alignment with a checking scope. Then run the appropriate diagnostic tests to ensure proper electrical and mechanical drive operation.
6. Although cartridges recorded on RK03s and RK05s are fully interchangeable, allow them to stabilize before new data is recorded on them. Data interchangeability between drives is only guaranteed if the temperature difference does not exceed 30° F (17° C), even though a specific drive/cartridge combination may operate over a temperature range of 50° to 110° F (10° to 43° C).

2.3 CARTRIDGE HANDLING PRACTICES AND PRECAUTIONS

To obtain maximum performance and high reliability from the RK05 Disk Drive, the following precautions and cartridge-handling practices must be observed:

1. Store cartridges in a clean, dry area away from direct sunlight. Do not expose cartridges to heat. They may be stored on edge or stacked; however, stacks of more than 3 or 4 cartridges should be avoided. Do not place heavy items on the plastic cartridge cases. Do not store cartridges on top of computer cabinets or in places where dirt can be blown by fans into cartridge interiors.
2. Whenever a cartridge is not in a drive, enclose it in a plastic bag to exclude dust or dirt.
3. Professional cartridge disassembly and cleaning is required every six months; however, disks should be cleaned whenever they are excessively dirty, or when a high transient error rate is encountered. In such instances, a disk-cleaning service, listed by Digital Equipment Corporation, should be contacted at once.
4. Place stiff cardboard or plastic labels only in the molded frame at the front edge of the disk cartridge without using any adhesives. Labels placed on any other part of the cartridge may interfere with the drive operation or introduce contamination into the drive or the interior of the cartridge.
5. Allow the temperature of the cartridge to become stabilized with the room temperature before using the cartridge. If cartridges are exposed to outside temperature extremes, or if the temperature differential between drive and cartridge exceeds 20° F, a two-hour stabilization period is necessary.
7. Keep the spindle hub clean and free from nicks and burrs to ensure reliable cartridge operation. Because the hub is slightly magnetic, do not expose it to metal chips that could adhere to the mounting surface. Periodically inspect the coupling hub on the bottom of the disk cartridge for dirt, metal chips, plastic chips in cone, etc.
8. A sustained tinging, scratching, or rumbling sound (*not* to be confused with spindle ground brushes) that is the result of head-to-disk contact may occur if the cartridge is not properly seated on the spindle, if excessive contamination has built up in the interior of the cartridge, or if the cartridge or the drive is defective. If this sound is heard, shut down the drive immediately to avoid damage to the read/write heads. Remove the disk cartridge and examine the heads for damage or excessive dirt. If necessary, clean or replace the heads. Do not reuse the cartridge without first checking it for surface damage.
9. Always keep the front door of the drive closed and keep all covers on to prevent unnecessary entry of atmospheric dirt or dust.

CAUTION
NEVER CYCLE A BAD CARTRIDGE THROUGH AN INSTALLATION OF SEVERAL DRIVES. This practice can ruin all the read/write heads or contaminate all drives in a multidrive installation, which will, in turn, damage all other cartridges run in these drives.

2.4 CARTRIDGE PACKING AND SHIPPING

Data recorded on disk cartridges may be degraded by exposure to any sort of small magnet brought into intimate contact with the disk surface. If cartridges are to be shipped in the cargo hold of an aircraft, precautions are necessary against possible exposure to magnetic sources. Because physical separation from the magnetic source is the best

protection against accidental erasure of a cartridge, cartridges should be packed at least three inches within the box. This amount of separation should be adequate to protect against any magnetic sources likely to be encountered during transportation, making it generally unnecessary to ship cartridges in specially shielded boxes.

2.5 NORMAL OPERATING PROCEDURES

All drives in a multidrive system must have operating power applied even when the drive is not in use. In addition, unused drives should be left write-enabled, and with the RUN/LOAD switch in the LOAD position.

IMPORTANT: ON EARLIER MODEL RK05 DISK DRIVES EQUIPPED WITH A POWER ON/OFF SWITCH, DO NOT USE THE ON/OFF SWITCH DURING SYSTEM OPERATION TO REMOVE OPERATING POWER FROM AN INDIVIDUAL DRIVE.

Because the DC LOW interface signal is common to all drives in a multidrive system, a power loss in any one drive disables all the drives in the system. If the drive power is controlled by a processor keyswitch, all drive ON/OFF switches should be left ON; however, all RUN/LOAD switches should be set to LOAD before system power is removed.

2.5.1 Cartridge Loading

The procedure for cartridge loading is as follows:

1. Set the RUN LOAD switch on all drives to LOAD and observe that the LOAD indicator lights.

CAUTION

If the LOAD indicator is not lit, the drive front door is locked. In this case, do not attempt to force the front door open.

2. Open the front door of the drive and *gently* insert a clean, operable disk cartridge fully into the cartridge receiver. **DO NOT TWIST OR FORCE THE CARTRIDGE DURING INSERTION!**
3. Close the front door of the drive and set the RUN/LOAD switch to RUN.
4. Wait for the RDY and ON CYL indicators to light, the drive is now ready to perform seek, read, or write operations.

2.5.2 Cartridge Unloading

The procedure for cartridge unloading is as follows:

1. Set the RUN/LOAD switch to LOAD and observe that the RDY indicator goes out. After approximately 30 seconds, the LOAD indicator will light.
2. Open the drive front door and *gently* withdraw the disk cartridge.
3. If another cartridge is not loaded, close the drive front door to prevent unnecessary entry of atmospheric dirt or dust.
4. Store the cartridge in a clean plastic bag.